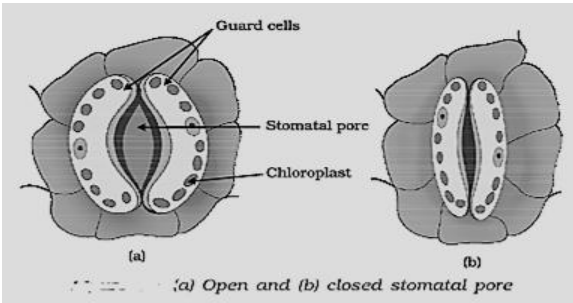
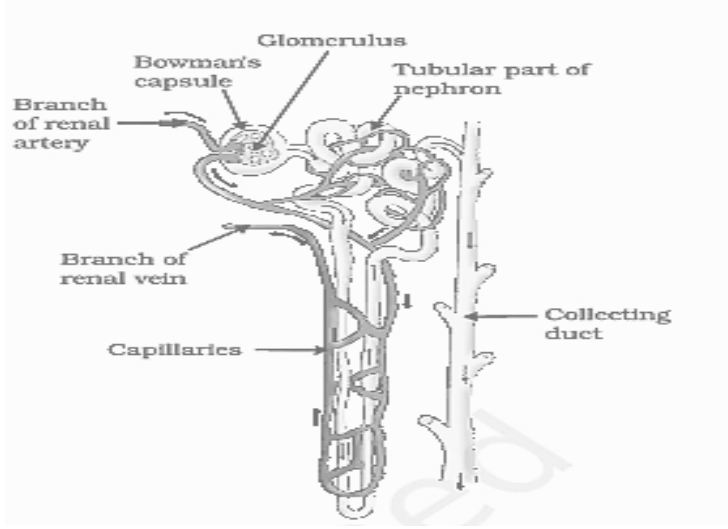

MARKING SCHEME
SCIENCE (Subject Code-086)
(PAPER CODE : 31/4/3) (10-04-86K)

Q.No.	EXPECTED OUTCOMES/VALUE POINTS	Marks	Total Marks
	SECTION – A Biology		
1.	(B) / (iv)	1	1
2.	(C) / By breaking down the nutrients of bread outside the body and then absorbing them.	1	1
3.	(C) / Formation of fruit	1	1
4.	(D) / Mammals	1	1
5.	(D) / Organic substance from leaves to the other parts of the plant.	1	1
6.	(D) / Contraction of Left Ventricle.	1	1
7.	(B) / (i) and (iv)	1	1
8.	(A) / Both Assertion (A) and Reason(R) are true and Reason(R) is correct explanation of Assertion (A).	1	1
9.	(C) / Assertion(A) is true, but Reason(R) is false.	1	1
10.	<ul style="list-style-type: none"> • Decomposers are organisms that break down dead and decaying organic matter into simpler inorganic substances. • Roles: <ul style="list-style-type: none"> ➤ Environment clean up ➤ Nutrient recycling <p style="text-align: right;">(or any other relevant point)</p>	1 ½ ½	2
11.	<ul style="list-style-type: none"> • Food: <ul style="list-style-type: none"> ▪ P – Glucose ▪ Q – Starch • Raw materials: CO₂, H₂O • Conditions: Presence of sunlight, chlorophyll 	½ ½ ½ ½	2
12.	<p>(A)</p> <ul style="list-style-type: none"> • As his pancreatic duct is blocked, enzymes for digestion will not be transported to small intestine / The blockage will cause difficulty in digestion of proteins, carbohydrates and fats. • Insulin secretion is already affected. <p style="text-align: center;">OR</p> <p>(B)</p> <ul style="list-style-type: none"> • Reflex action • An automatic and quick response to a stimulus which does not involve thinking. • Stimulus → Receptor → sensory neuron → relay neuron (spinal cord) → Motor neuron → effector (muscle) response. 	1 1 ½ ½ 1	2

<p>15.</p>	<p>(a) Due to hydrotropism, the roots grow towards area of water availability so that they can absorb water and minerals.</p> <p>(b) Auxins promote cell elongation / Auxin regulates the tropic responses like bending (growth) of stem towards light.</p> <p>(c)</p> <table border="1" data-bbox="310 373 1195 569"> <thead> <tr> <th>Movement by sensitive plants</th> <th>Tropic Movements by plants</th> </tr> </thead> <tbody> <tr> <td>Non-directional</td> <td>Directional</td> </tr> <tr> <td>Fast</td> <td>Slow</td> </tr> <tr> <td>Growth independent movement</td> <td>Growth related</td> </tr> </tbody> </table> <p>(Any two points and any other difference)</p> <p style="text-align: center;">OR</p> <p>(c)</p> <table border="1" data-bbox="180 785 1268 980"> <thead> <tr> <th>Movement of Roots</th> <th>Movement of Shoots</th> </tr> </thead> <tbody> <tr> <td>Gravity: Grows towards gravity / Positive geotropism</td> <td>Gravity: Grows away from gravity / Negative geotropism</td> </tr> <tr> <td>Light: Grows away from light / Negative phototropism</td> <td>Light: Grows towards light/ Positive phototropism</td> </tr> </tbody> </table>	Movement by sensitive plants	Tropic Movements by plants	Non-directional	Directional	Fast	Slow	Growth independent movement	Growth related	Movement of Roots	Movement of Shoots	Gravity: Grows towards gravity / Positive geotropism	Gravity: Grows away from gravity / Negative geotropism	Light: Grows away from light / Negative phototropism	Light: Grows towards light/ Positive phototropism	<p>1</p> <p>1</p> <p>1</p> <p>1</p> <p>1</p> <p>1</p> <p>1</p> <p>4</p>	
Movement by sensitive plants	Tropic Movements by plants																
Non-directional	Directional																
Fast	Slow																
Growth independent movement	Growth related																
Movement of Roots	Movement of Shoots																
Gravity: Grows towards gravity / Positive geotropism	Gravity: Grows away from gravity / Negative geotropism																
Light: Grows away from light / Negative phototropism	Light: Grows towards light/ Positive phototropism																
<p>16.</p>	<p>(A)</p> <p>(a)</p>  <p>(b)</p> <ul style="list-style-type: none"> • Absorption of light energy by chlorophyll. • Conversion of light energy to chemical energy and splitting of water molecule into hydrogen and oxygen. • Reduction of carbon dioxide to carbohydrates <p>(c)</p> <div style="background-color: #e0e0e0; padding: 10px; text-align: center;"> $6\text{CO}_2 + 12\text{H}_2\text{O} \xrightarrow[\text{Sunlight}]{\text{Chlorophyll}} \text{C}_6\text{H}_{12}\text{O}_6 + 6\text{O}_2 + 6\text{H}_2\text{O}$ <p>(Glucose)</p> </div> <p style="text-align: center;">OR</p>	<p>1 + 1</p> <p>2</p> <p>1</p>															

<p>(B) (a)</p>	 <p style="text-align: right;">Diagram Labelling of any 4 parts</p> <p>(b) Filtration of blood to remove wastes.</p> <p>(c) It is a process by which useful substances like glucose, amino acids, vitamins, salts and most of water are reabsorbed from filtrate, back into the blood.</p>	<p style="text-align: center;">1 ½ x 4</p> <p style="text-align: center;">1</p> <p style="text-align: center;">1</p>	<p style="text-align: center;">5</p>
SECTION – B			
Chemistry			
17.	(B)/ Hydrochloric acid	1	1
18.	(A)/ The hydrophobic tail of the soap molecule is in the interior of the cluster, whereas hydrophilic end is on the surface of the cluster.	1	1
19.	(D)/ Magnesium	1	1
20.	(C)/ Exothermic Reaction	1	1
21.	(B)/ 2 : 1	1	1
22.	(C)/ Lead and Tin	1	1
23.	(B)/ Sodium Hydrogen Carbonate	1	1
24.	(A)/ Both A and R is true and R is correct explanation of A.	1	1
25.	<p>(a)</p> $2\text{NaCl}(\text{aq}) + 2\text{H}_2\text{O}(\text{l}) \rightarrow 2\text{NaOH}(\text{aq}) + \text{Cl}_2(\text{g}) + \text{H}_2(\text{g})$ <p>(b) $2\text{NaHCO}_3 \xrightarrow{\text{Heat}} \text{Na}_2\text{CO}_3 + \text{H}_2\text{O} + \text{CO}_2$ (Deduct ½ mark for no/ incorrect balancing)</p>	<p style="text-align: center;">1</p> <p style="text-align: center;">1</p>	2

<p>26.</p>	<p>(A)</p> <p>(i) (a) Carbonate ore: Calcination $\text{ZnCO}_3(\text{s}) \xrightarrow{\text{Heat}} \text{ZnO}(\text{s}) + \text{CO}_2(\text{g})$</p> <p>(b) Sulphide ore: Roasting $2\text{ZnS}(\text{s}) + 3\text{O}_2(\text{g}) \xrightarrow{\text{Heat}} 2\text{ZnO}(\text{s}) + 2\text{SO}_2(\text{g})$</p> <p>(ii)</p> $\text{Fe}_2\text{O}_3(\text{s}) + 2\text{Al}(\text{s}) \rightarrow 2\text{Fe}(\text{l}) + \text{Al}_2\text{O}_3(\text{s}) + \text{Heat}$ <p>(iii)</p> <ul style="list-style-type: none"> • Anode: Impure copper rod. • Cathode: Pure copper strip. <p style="text-align: center;">OR</p> <p>(B)</p> <p>(i)</p> $2\text{ZnS}(\text{s}) + 3\text{O}_2(\text{g}) \xrightarrow{\text{Heat}} 2\text{ZnO}(\text{s}) + 2\text{SO}_2(\text{g})$ $\text{ZnO}(\text{s}) + \text{C}(\text{s}) \rightarrow \text{Zn}(\text{s}) + \text{CO}(\text{g})$ <p>(ii) Nitric acid is a strong oxidising agent and oxidises H₂ gas produced to water.</p>	<p>½</p> <p>½</p> <p>1</p> <p>½</p> <p>½</p> <p>1</p> <p>1</p> <p>1</p>	<p>3</p>
<p>27.</p>	<p>(a)</p> <ul style="list-style-type: none"> • Green colour of the crystal changes brown. • Colourless gases with odour of burning sulphur. <p style="text-align: right;">(any other observation)</p> <p>(b) Copper changes to copper (II) oxide which is black in colour./</p> $\underset{\text{Brown}}{2\text{Cu}(\text{s})} + \text{O}_2(\text{g}) \xrightarrow{\text{Heat}} \underset{\substack{\text{Copper(II) Oxide} \\ \text{(Black)}}}{2\text{CuO}(\text{s})}$ <p style="text-align: center;">(Award full marks if chemical equation with colour changes is written)</p> <p>(c) Calcium oxide (quick lime) and colourless gas (CO₂) is evolved) /</p> $\text{CaCO}_3(\text{s}) \xrightarrow{\text{Heat}} \text{CaO}(\text{s}) + \text{CO}_2(\text{g})$	<p>½</p> <p>½</p> <p>1</p> <p>1</p>	<p>3</p>

28.	(a) Universal indicator (b) A/ (pH = 3) (c) <ul style="list-style-type: none"> • Strong acids give more H⁺ ions in water. • Weak acids give less H⁺ ions in water. <p style="text-align: center;">OR</p> (c) (i) When pH < 5.6 (ii) Weak acid: acetic acid, formic acid	1 1 1 1 1 1/2 + 1/2	4
29.	(A) (i) Carbon cannot form C ⁴⁺ cation because removal of four electrons is energetically not possible. Carbon cannot form C ⁴⁻ anion because nucleus with six protons cannot hold ten electrons. (ii) <ul style="list-style-type: none"> • A series of compounds in which the same functional group substitutes for hydrogen in carbon chain is called a homologous series. • Because of higher molecular mass of C₄H₁₀ than C₃H₈ or C₂H₆. (iii) Ethanoic acid / acetic acid / CH ₃ COOH is formed / $\text{CH}_3 - \text{CH}_2\text{OH} \xrightarrow[\text{Or acidified K}_2\text{Cr}_2\text{O}_7 + \text{Heat}]{\text{Alkaline KMnO}_4 + \text{Heat}} \text{CH}_3\text{COOH}$ <p style="text-align: center;">OR</p> (B) (i) I. Propanal II. Propyne (ii) I. Ester group II. $\text{CH}_3 - \text{COOH} + \text{CH}_3 - \text{CH}_2\text{OH} \xrightarrow{\text{Acid}} \text{CH}_3 - \underset{\text{O}}{\text{C}} - \text{O} - \text{CH}_2 - \text{CH}_3 + \text{H}_2\text{O}$ (iii) Soaps reacts with calcium and magnesium salts present in hard water to form scum (insoluble substance).	2 1 1 1 1 1 1 1	5
SECTION – C			
Physics			
30.	(A) / Iris and pupil	1	1
31.	(C) / Presbyopia	1	1
32.	(A) / Both Assertion (A) and Reason (R) both are true, and Reason (R) is the correct explanation of Assertion	1	1

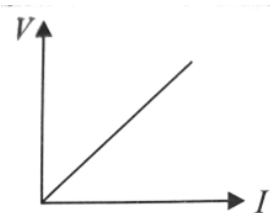
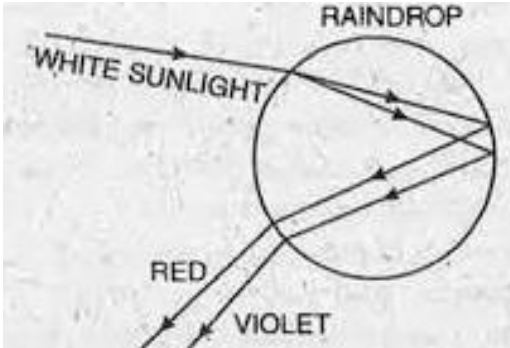
<p>33.</p>	<p>(A)</p> <ul style="list-style-type: none"> $I = \frac{P}{V}$ $I = \frac{2000}{200}$ $I = 10 \text{ A}$ Current passing through electric heater is 10A which is much more than rated value (4A) of fuse. Hence fuse will melt and break the circuit. So, it cannot be used. <p style="text-align: center;">OR</p> <p>(B)</p> <ul style="list-style-type: none"> An electromagnet is formed by wrapping a current carrying insulated copper wire in the form of coil around a magnetic material like soft iron core. / By placing a magnetic material like soft iron as a core material inside the current carrying solenoid. Strength of electromagnet can be increased by increasing the <ul style="list-style-type: none"> (i) Number of turns of coil (ii) Current flowing through the coil. 	<p>$\frac{1}{2}$</p> <p>$\frac{1}{2}$</p> <p>1</p> <p>1</p> <p>$\frac{1}{2}$</p> <p>$\frac{1}{2}$</p>	<p>2</p>
<p>34.</p>	<p>(i) The potential difference, V, across the ends of a given metallic wire in an electric circuit is directly proportional to the current, I flowing through it, provided its temperature remains the same</p> <p>(ii)</p> 	<p>1</p> <p>1</p>	<p>2</p>
<p>35.</p>	<p>Rainbow is caused by dispersion of sunlight by tiny water droplets, present in the atmosphere. The water droplets act like small prisms. They refract and disperse the incident sunlight, then reflect it internally, and finally refract it again when it comes out of the raindrop.</p> 	<p>2</p> <p>1</p>	<p>3</p>

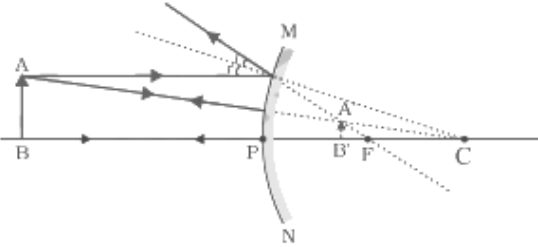
36.	<p>(a)</p> <ul style="list-style-type: none"> The rod AB gets displaced from its original position Because it experiences a force when placed in external magnetic field <p>(b)</p> <ul style="list-style-type: none"> Fleming's Left Hand Rule Stretch the thumb, fore finger and middle finger of your left hand such that they are mutually perpendicular. If forefinger points in the direction of magnetic field, second finger in the direction of current, then the thumb will point in the direction of motion or force acting on the conductor. 	<p>½</p> <p>½</p> <p>1</p> <p>1</p>	3
37.	<p>(a) $f = + 2m$ $u = - 8m$</p> $\frac{1}{v} + \frac{1}{u} = \frac{1}{f}$ $\frac{1}{v} = \frac{1}{f} - \frac{1}{u}$ $\frac{1}{v} = \frac{1}{2} + \frac{1}{8}$ $v = \frac{8}{5} = 1.6 m$ <p>The image is formed 1.6m behind the mirror</p> <p>(b)</p> 	<p>½</p> <p>½</p> <p>1</p> <p>1</p>	3
38.	<p>(a) Real / magnified.</p> <p>(b) Converging / Concave mirror, Plane mirror</p> <p>(c)</p> <ul style="list-style-type: none"> Convex lens It magnifies the image formed by the curved mirror <p style="text-align: center;">OR</p> <p>(c) The plane mirror redirects/ reflects the light rays coming from the curved mirror towards eyepiece.</p>	<p>1</p> <p>1</p> <p>1</p> <p>1</p> <p>2</p>	4

39. (A) (i)

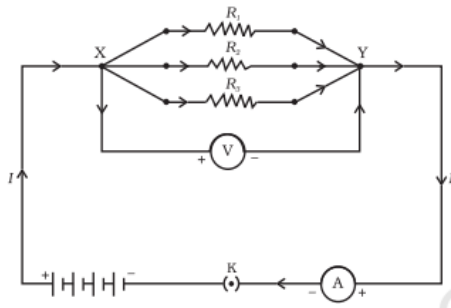

As in parallel combination, potential difference applied across each resistor is same.
Current flowing through each resistor R_1 , R_2 and R_3 is

$$I_1 = \frac{V}{R_1}, I_2 = \frac{V}{R_2}, I_3 = \frac{V}{R_3}$$

If resistance of parallel combination is R_p , then current drawn from battery is

$$I = \frac{V}{R_p}$$

Current, $I = I_1 + I_2 + I_3$

$$\frac{V}{R_p} = \frac{V}{R_1} + \frac{V}{R_2} + \frac{V}{R_3}$$

$$\frac{1}{R_p} = \frac{1}{R_1} + \frac{1}{R_2} + \frac{1}{R_3}$$

(ii) As all the resistors are connected in parallel, the potential difference applied across each resistor is 12V

$$V = IR$$

$$I_1 = \frac{V}{R_1} = \frac{12}{2} = 6A$$

$$I_2 = \frac{12}{4} = 3A$$

$$I_3 = \frac{12}{6} = 2A$$

OR

(B)

(i) Resistivity is the resistance offered by a wire of unit length and unit area of cross section in an electric circuit.

(ii)

- Resistivity of conducting wire will remain same.
- Resistivity is the characteristic property of the material.
- Resistance will remain same

1

1/2

1/2

1

1/2

1/2

1/2

1/2

5

	<ul style="list-style-type: none"> • $R = \rho \frac{l}{A}$ <p>If $l' = 2l$ $A' = 2A$</p> $R' = \rho \frac{l'}{A'}$ $R' = \rho \frac{2l}{2A}$ $R' = R$ <p>(iii) $H = I^2 R t$</p> $I = \sqrt{\frac{H}{R t}}$ $I = \sqrt{\frac{100}{4 \times 1}}$ $I = 5A$	<p style="text-align: center;">$\frac{1}{2}$</p> <p style="text-align: center;">1</p>	<p style="text-align: center;">1</p> <p style="text-align: center;">5</p>
- o O o -			